



- + Capacity: 24 bottles*
- + Built-in column
- + Design: black body & black piano organic glass door frame
- + Cooling system: compressor
- + Type of cold: air moving system
- + Adjustable temperature range of use: 5°-18°C
- + Electronic regulation
- + Thermometer with white electronic display
- + White LED lights with switch button
- + Humidity control: natural (hygrodynamic concept)
- + 1 glass door, anti-UV treated, 2-layers tempered E-Low glass (grey-colored)

- **Mechanical Push-pull system:** no need for a handle to open and close your door. A slight bit of pressure on the top corner on the left side and it's done!



Eco-responsibility

Our products are manufactured in compliance with European environmental rules. Especially, refrigerant fluid (R600a) doesn't reject neither CFC nor HFC and respect environment.

Energy consumption is calculated based on the result obtained for 24h in standard test conditions. The actual energy consumption depends on the conditions of use and location of the device.

This equipment is designed to be used in an ambient temperature between 10°-32°C.

This appliance is intended to be used exclusively for the storage of wine.

Alcohol abuse is dangerous for health, please consume in moderation.

*Capacity given as an indication with 75cl Bordeaux traditional type bottles and measured with 3 shelves. Adding shelves reduce considerably the total capacity.



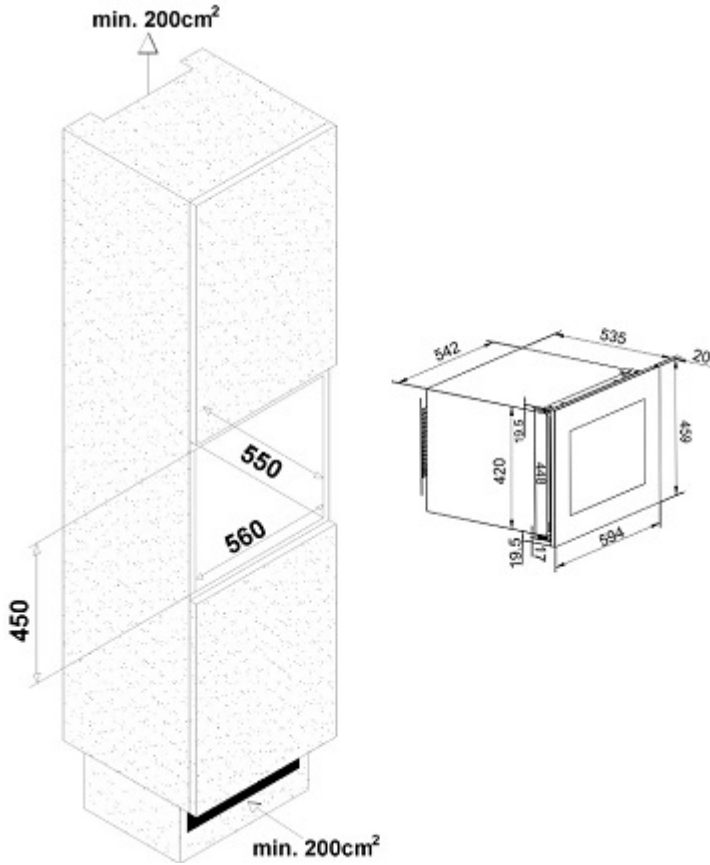

> EQUIPMENTS INCLUDED

- 3 semi-sliding wooden shelves
- 2 adjustable feet (height 2 cm)
- Anti-vibration system

> TECHNICAL CHARACTERISTICS

- Energy class: G
- Annual electrical consumption: 152 kWh
- Climatic class: N-SN
- Noise level: 38 dB
- EEI: 188.0
- Voltage: 220-240 V
- Power input: 85 W
- Category: 2 - Wine cellar
- Type of gas: R600a

> LOGISTIC DATAS

Gross dimensions (WxDxH cm)	: 65 x 65 x 51,5
Net dimensions (WxDxH cm)	: 59,4 x 55,5 x 45,9
Gross weight (kg)	: 32.00
Net weight (kg)	: 28.00
Full truck (pcs)	: 180
Container (pcs)	20' : 108
	40' : 216
	40' HC : 270

Gencod 3595320103748

> COMPATIBLE ACCESSORIES

Only available in spare parts